

Type BSSD Load Cell

“S” Type



Features 主要特点

- S-Type load cell
- Senior alloy steel
- Easy to install, stabile & reliable
- Suitable for tension measurement, batching systems, and architecture machine, etc.
- S型传感器
- 优质合金钢材质
- 安装简便、快速,稳定可靠
- 适用于材料试验机、配料秤和建筑机械等

Schematic 接线方式

Red :	+ input	红色 :	+ 激励
Black :	- input	黑色 :	- 激励
Green :	+ output	绿色 :	+ 信号
White :	- output	白色 :	- 信号

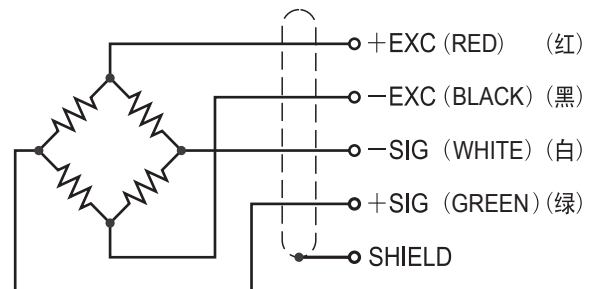

Capacities 量程

5t, 15t, 20t

Dimensions 尺寸

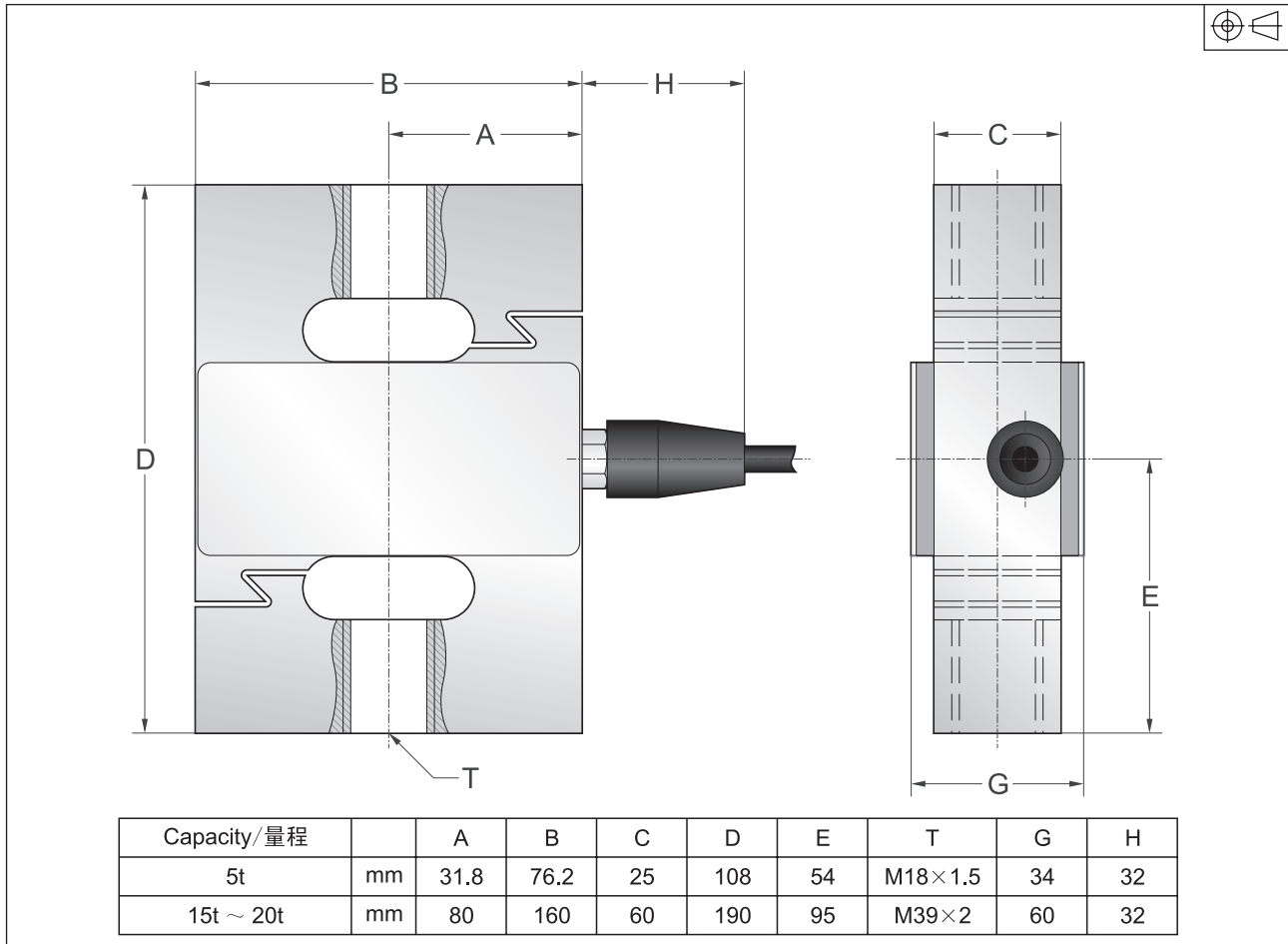

“S” Type

Specification 技术参数

Rated Output	额定输出	2.0mV/V ±0.1%
Zero Balance	零点平衡	±1% of rated output
Creep after 30 minutes	蠕变	±0.03% of rated output
Nonlinearity	非线性	±0.03% of rated output
Hysteresis	滞后	±0.03% of rated output
Repeatability	重复性	±0.03% of rated output
Temp. effect on output	灵敏度温漂	≤0.002% of applied output/°C
Temp. effect on zero	零点温漂	≤0.002% of rated output/°C
Safe Temp. Range	可用温度范围	-10°C to + 70°C
Temp. Compensated	温度补偿范围	-10°C to + 40°C
Safe Overload	安全载荷	150%
Input Impedance	输入阻抗	387 ohm ± 20 ohm
Output Impedance	输出阻抗	350 ohm ± 5 ohm
Insulation Resistance	绝缘阻抗	≥5000 M ohm (50V DC)
Rated Excitation	推荐激励电压	10V DC/AC
Maximum Excitation	最大激励电压	15V DC/AC
Cable Length	导线长度	6m
Cable Color Code	导线颜色	Red(+ E) Black(- E) Green(+ S) White(- S)